

COLLIERS DE RÉPARATION - MONO BANDE (UN SERRAGE)

REPAIR CLAMPS - SINGLE BAND

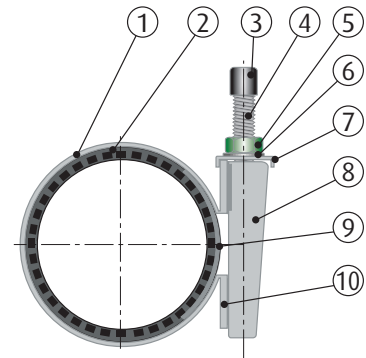
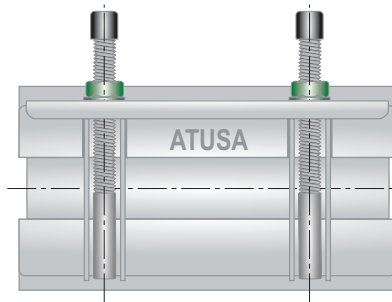

DESCRIPTION DES COMPOSANTS - COMPONENTS DESCRIPTION

Index - Ítem	Description - Description	Matière - Material
1	Corps - Body	Acier inoxydable - Stainless Steel AISI 304
2	Joint - Gasket	EPDM
3	Capuchon de protection - Protection cap	Plastique - Plastic
4	Boulons - Studs	Acier inoxydable - Stainless Steel AISI 304
5	Écrous hexagonaux - Hexagonal nuts	Acier inoxydable - Stainless Steel AISI 304
6	Anilhas planas - Fingers	Acier inoxydable - Stainless Steel AISI 304
7	Pont - Bridge	Acier inoxydable - Stainless Steel AISI 304
8	Guides - Fingers	Acier inoxydable - Stainless Steel AISI 304
9	Plaque de fermeture - Spanner plate	Acier inoxydable - Stainless Steel AISI 304
10	Plaque latérale - Side plate	Acier inoxydable - Stainless Steel AISI 304

CARACTERISTIQUES

- Pression de travail maximale: 10 - 16 bar.
- Temperature de travail maximale: 120 °C.
- Fabrication complète en acier inoxydable AISI 304.
- Joint EPDM avec structure alvéolaire.
- Boulons en acier inoxydable.

DOMAINES D'APPLICATION

- Pour réparer des tubes en acier, fonte, fibrociment, PE et PVC (eau seulement).

Remarques:

Étant donné la complexité, la variété et le grand nombre de spécifications particulières de chaque installation, conjugués à l'existence de divers facteurs pouvant affecter les conditions de travail et la nature du produit, il incombe à l'utilisateur final d'effectuer les tests nécessaires pour assurer un bon fonctionnement du produit dans chaque domaine d'application.

L'installation du produit doit être effectuée et entretenue conformément aux bonnes pratiques et aux normes en vigueur.

BASIC FEATURES

- Maximum working pressure: 10 - 16 bar.
- Maximum working temperature: 120 °C.
- Manufactured entirely in stainless steel AISI 304.
- Sealing gasket of EPDM rubber with grid structure.
- Studs in stainless steel.

GENERAL APPLICATIONS

- For quick repairs on steel, cast iron, asbestos cement, PE and PVC (only water).

Remarks:

Due to the complexity, variety and large number of particular specifications for each installation, along with the existence of diverse factors which can affect the working conditions and nature of the product, it is the responsibility of the end-user to carry out the necessary tests to ensure the proper functioning of the product in any specific application.

Product installation must be carried out and maintained following the good practice codes and/or updated technical standards.

Rev.0-05.24

1/2



Polígono Industrial ATUSA - Agurain S/N - 01200 Salvatierra (Alava) España
 Tel.: (+34) 945 18 00 00 Fax : (+34) 945 30 01 53 e-mail: ventas@atusagroup.com
www.atusagroup.com

COLLIERS DE RÉPARATION - MONO BANDE (UN SERRAGE)

REPAIR CLAMPS - SINGLE BAND

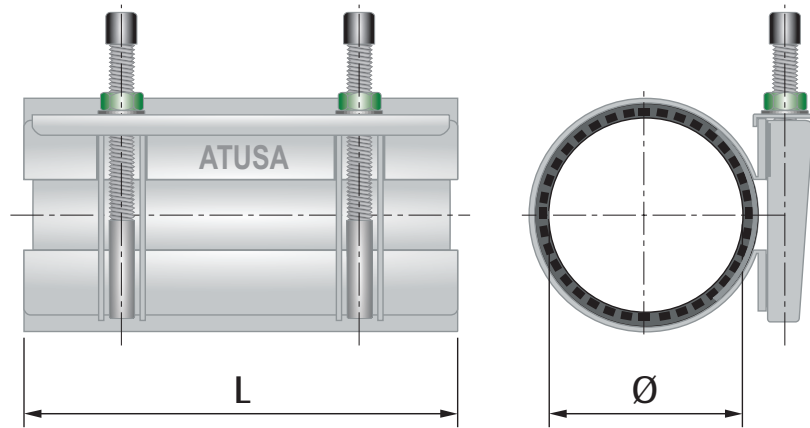

INFORMATION TECHNIQUE - TECHNICAL INFORMATION

CODE	Pression maximale Maximum pressure	DIMENSIONS - DIMENSIONS		Boulons - Bolting		Poids approx. Weight approx. (Kg)
		Tolérance diamétrale Diametrical tolerance	Longueur Length	Nombre Number	Diamètre Diameter	
	(bar)	Ø (mm)	L (mm)	nr (n°)	Ø (mm)	
VF812048	16	48-55	200	2	M14	1,6
VF812052	16	52-59	200	2	M14	1,6
VF812060	16	60-67	200	2	M14	1,6
VF812067	16	67-74	200	2	M14	1,7
VF812073	16	73-80	200	2	M14	1,8
VF812082	16	82-90	200	2	M14	1,8
VF812087	16	87-94	200	2	M14	1,9
VF812095	16	95-105	200	2	M14	1,9
VF812108	16	108-118	200	2	M14	2,0
VF812118	16	118-128	200	2	M14	2,1
VF812135	16	135-145	200	2	M14	2,2
VF812145	16	145-155	200	2	M14	2,3
VF812151	16	151-161	200	2	M14	2,4
VF812165	16	165-175	200	2	M14	2,4
VF812176	16	176-186	200	2	M14	2,5
VF812193	16	193-203	200	2	M14	2,6
VF812200	10	200-212	200	2	M14	2,9
VF812219	10	219-229	200	2	M14	3,0

Note : En raison de l'évolution constante de nos produits, ces spécifications peuvent être modifiées sans préavis.

Note : Due to the continuous development of our products, specifications may be changed without notification at any time.

Rev.0-05.24
2/2



Polígono Industrial ATUSA - Agurain S/N - 01200 Salvatierra (Alava) España
Tel.: (+34) 945 18 00 00 Fax : (+34) 945 30 01 53 e-mail: ventas@atusagroup.com
www.atusagroup.com