

# BRIDA ROSCADA FORJADA EN 1092-1 Tipo 13 - PN 6/16/40

## FORGED THREADED FLANGE EN 1092-1 Type 13 - PN 6/16/40

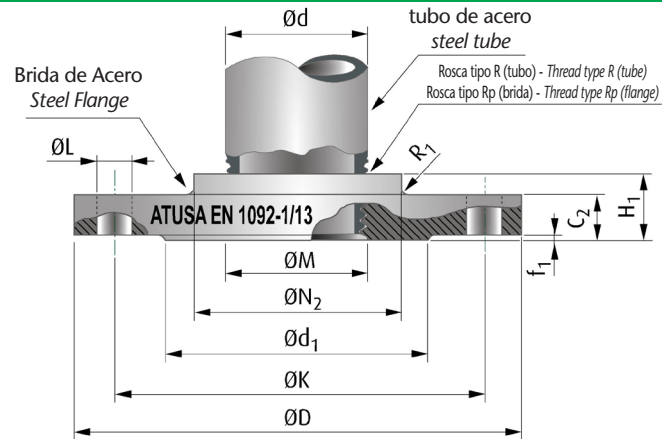

PN 6/16/40



### INFORMACIÓN TÉCNICA - TECHNICAL INFORMATION

Designación - Designation	Brida - Flange													Cara - Face		Tornillos - Bolting		Peso aprox. Weight approx. (kg)
	Tubo de Acero Steel tube			PN	Medida de la rosca Thread size	Diámetro exterior Outside diameter	Diámetro del círculo para tornillos Diameter of bolt circle	Diámetro para tornillo Diameter of bolt hole	Altura Height	Espesor Thickness	Diámetro del cuello Neck diameter	Radio del cuello Neck radius	Diámetro Diameter	Altura Height	Número Number	Diámetro Diameter		
	DN	NPS	Ød (mm)														ØM	
FC130015	15	1/2"	21,3	6	Rp 1/2"	80 ± 2,0	55 ± 1,0	11 +1,0/0	20 ± 1,5	12 +1,0/-1,3	30	4	40	2	4	M10	0,37	
FC134015	15	1/2"	21,3	40	Rp 1/2"	95 ± 2,0	65 ± 1,0	14 +1,0/0	22 ± 1,5	16 +1,0/-1,3	35	4	45	2	4	M12	0,72	
FC130020	20	3/4"	26,9	6	Rp 3/4"	90 ± 2,0	65 ± 1,0	11 +1,0/0	24 ± 1,5	14 +1,0/-1,3	40	4	50	2	4	M10	0,58	
FC134020	20	3/4"	26,9	40	Rp 3/4"	105 ± 2,0	75 ± 1,0	14 +1,0/0	26 ± 1,5	18 +1,0/-1,3	45	4	58	2	4	M12	1,04	
FC130025	25	1"	33,7	6	Rp 1"	100 ± 2,0	75 ± 1,0	11 +1,0/0	24 ± 1,5	14 +1,0/-1,3	50	4	60	2	4	M10	0,73	
FC134025	25	1"	33,7	40	Rp 1"	115 ± 2,0	85 ± 1,0	14 +1,0/0	28 ± 1,5	18 +1,0/-1,3	52	4	68	2	4	M12	1,25	
FC130032	32	1 1/4"	42,4	6	Rp 1 1/4"	120 ± 2,0	90 ± 1,0	14 +1,0/0	26 ± 1,5	14 +1,0/-1,3	60	6	70	2	4	M12	1,04	
FC134032	32	1 1/4"	42,4	40	Rp 1 1/4"	140 ± 2,0	100 ± 1,0	18 +1,0/0	30 ± 1,5	18 +1,0/-1,3	60	6	78	2	4	M16	1,81	
FC130040	40	1 1/2"	48,3	6	Rp 1 1/2"	130 ± 2,0	100 ± 1,0	14 +1,0/0	26 ± 1,5	14 +1,0/-1,3	70	6	80	3	4	M12	1,20	
FC134040	40	1 1/2"	48,3	40	Rp 1 1/2"	150 ± 2,0	110 ± 1,0	18 +1,0/0	32 ± 1,5	18 +1,0/-1,3	70	6	88	3	4	M16	2,06	
FC130050	50	2"	60,3	6	Rp 2"	140 ± 2,0	110 ± 1,0	14 +1,0/0	28 ± 1,5	14 +1,0/-1,3	80	6	90	3	4	M12	1,34	
FC136050	50	2"	60,3	16	Rp 2"	165 ± 2,0	125 ± 1,0	18 +1,0/0	32 ± 1,5	18 +1,0/-1,3	84	6	102	3	4	M16	2,39	
FC130065	65	2 1/2"	76,1	6	Rp 2 1/2"	160 ± 2,0	130 ± 1,0	14 +1,0/0	32 ± 1,5	14 +1,0/-1,3	100	6	110	3	4	M12	1,83	
FC136065	65	2 1/2"	76,1	16	Rp 2 1/2"	185 ± 2,0	145 ± 1,0	18 +1,0/0	32 ± 1,5	18 +1,0/-1,3	104	6	122	3	8	M16	2,97	
FC130080	80	3"	88,9	6	Rp 3"	190 ± 2,0	150 ± 1,0	18 +1,0/0	34 ± 1,5	16 +1,0/-1,3	110	8	128	3	4	M16	2,75	
FC136080	80	3"	88,9	16	Rp 3"	200 ± 2,0	160 ± 1,0	18 +1,0/0	34 ± 1,5	20 ± 1,5	118	6	138	3	8	M16	3,78	
FC130100	100	4"	114,3	6	Rp 4"	210 ± 2,0	170 ± 1,0	18 +1,0/0	40 ± 2,0	16 +1,0/-1,3	130	8	148	3	4	M16	3,01	
FC136100	100	4"	114,3	16	Rp 4"	220 ± 2,0	180 ± 1,0	18 +1,0/0	40 ± 2,0	20 ± 1,5	140	8	158	3	8	M16	4,38	
FC136125	125	5"	139,7	16	Rp 5"	250 ± 2,0	210 ± 1,0	18 +1,0/0	44 ± 2,0	22 ± 1,5	168	8	188	3	8	M16	6,57	
FC136150	150	6"	168,3	16	Rp 6"	285 ± 2,0	240 ± 1,0	22 +1,0/0	44 ± 2,0	22 ± 1,5	195	10	218	3	8	M20	7,24	

### CARACTERÍSTICAS BÁSICAS

- Brida conforme UNE-EN 1092-1 Tipo 13.
- Material: Acero P245GH conforme a UNE-EN 10222-2.
- Tipo de refrentado: Tipo B, Cara con Resalte.
- Rosca estanca según UNE EN 10226-1 y ISO 7-1 (tipo Rp).
- Todas las instalaciones deben cumplir los valores P-T según los requisitos legales especificados.
- Marcado: ATUSA; EN 1092-1/13; DN/Ød; MATERIAL; PN; N° COLADA.

### APLICACIONES GENERALES

- Sistemas de aguas generales.
- Plantas de abastecimiento, bombeo y acometidas de aguas.
- Aplicaciones industriales, aceites y gasóleo.
- Instalaciones Contra Incendios.

### BASIC FEATURES

- Flange according to EN 1092-1 Type 13.
- Material: Steel P245GH according to EN 10222-2.
- Flange facing type: Type B, Raised Face.
- Jointing thread according EN 10226-1 and ISO 7-1 (Rp type).
- All installations has to meet the P-T values specified in the legal requirements.
- Marking: ATUSA EN 1092-1/13; DN/Ød; MATERIAL; PN; HEAT Number.

### GENERAL APPLICATIONS

- Water systems.
- Water supply, pumping and connection plants.
- Industrial applications, oils and diesel.
- Fire Fighting Installations.

Rev.2-10.21  
1/2



Polígono Industrial ATUSA - Agurain S/N - 01200 Salvatierra (Alava) España  
Tel.: (+34) 945 18 00 00 Fax : (+34) 945 30 01 53 e-mail: [ventas@atusagroup.com](mailto:ventas@atusagroup.com)  
[www.atusagroup.com](http://www.atusagroup.com)

**BRIDA ROSCADA FORJADA EN 1092-1 Tipo 13 - PN 6/16/40**  
**FORGED THREADED FLANGE EN 1092-1 Type 13 - PN 6/16/40**



**Observaciones:**

Dada la complejidad, variedad y gran cantidad de especificaciones particulares de cada instalación, en conjunción con la existencia de diversos factores que pueden afectar a las condiciones de trabajo y naturaleza del producto, es responsabilidad del usuario final realizar los ensayos necesarios para garantizar el correcto funcionamiento del producto en cada aplicación concreta.

La instalación del producto deberá realizarse y mantenerse siguiendo códigos de buena práctica y/o estándares existentes.

**Remarks:**

*Due to the complexity, variety and large number of particular specifications for each installation, along with the existence of diverse factors which can affect the working conditions and nature of the product, it is the responsibility of the end-user to carry out the necessary tests to ensure the proper functioning of the product in any specific application.*

*Product installation must be carried out and maintained following the good practice codes and/or updated technical standards.*

Nota : Debido al constante desarrollo de nuestros productos, los datos suministrados pueden ser alterados sin previo aviso.

Note : Due to the continuous development of our products, specifications may be changed without notification at any time.

Rev.2-10.21

2/2



Polígono Industrial ATUSA - Agurain S/N - 01200 Salvatierra (Alava) España  
Tel.: (+34) 945 18 00 00 Fax : (+34) 945 30 01 53 e-mail: [ventas@atusagroup.com](mailto:ventas@atusagroup.com)  
[www.atusagroup.com](http://www.atusagroup.com)