

550

# VÁLVULA DE RETENCIÓN DE BOLA - BRIDADA

## BALL CHECK VALVE - FLANGED



CE

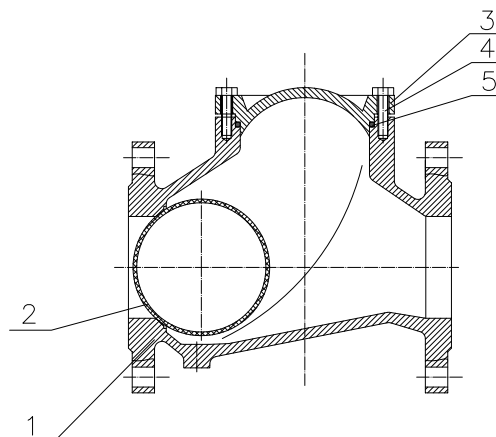

### DESCRIPCIÓN COMPONENTES - COMPONENTS DESCRIPTION

Ítem	Descripción - Description	Material - Material
1	Cuerpo - Body	Fundición Nodular - Ductile Iron GGG40 (EN-GJS-400-15)
2	Bola - Ball	DN40 - DN150: Aluminio - Aluminum + NBR DN200 - DN300: Fundición Nodular - Ductile Iron GGG40 (EN-GJS-400-15) + NBR
3	Tapa - Bonnet	Fundición Nodular - Ductile Iron GGG40 (EN-GJS-400-15)
4	Tornillos - Bolts	Acero Inoxidable - Stainless Steel A2
5	Junta - Gasket	NBR

### CARACTERÍSTICAS BÁSICAS

- Presión de trabajo: PN 16.
- Temperatura de trabajo: -10 °C a 80 °C.
- Bridas según: UNE-EN 1092-2 PN 10 / 16.
- Distancia entre bridas: DIN 3202-1 F6 (UNE-EN 558-1 Serie 48).
- Recubrimiento interior y exterior "EPOXY", 250 µm.
- Pruebas unitarias de presión según: UNE-EN 12266-1.
- Paso total, mínima pérdida de carga.
- Diseño unidireccional.
- Instalación horizontal o vertical.

### APLICACIONES GENERALES

- Depuración y bombeo de aguas residuales urbanas o industriales.
- Diseñada para líquidos contaminados, densos y viscosos.
- Aceites.

#### Observaciones:

Dada la complejidad, variedad y gran cantidad de especificaciones particulares de cada instalación, en conjunción con la existencia de diversos factores que pueden afectar a las condiciones de trabajo y naturaleza del producto, es responsabilidad del usuario final realizar los ensayos necesarios para garantizar el correcto funcionamiento del producto en cada aplicación concreta. La instalación del producto deberá realizarse y mantenerse siguiendo códigos de buena práctica y/o estándares existentes.

### BASIC FEATURES

- Working pressure: PN 16.
- Working temperature: -10 °C to 80 °C.
- Flange dimension: EN 1092-2 PN 10 / 16.
- Face to face dimension: DIN 3202-1 F6 (EN 558-1 Serie 48).
- Inside and outside "EPOXY" powder coating, 250 µm.
- Unit pressure tests: EN 12266-1.
- Full bore, minimum pressure drop.
- Unidirectional design.
- Horizontal or vertical working position.

### GENERAL APPLICATIONS

- Urban or industrial waste water pumping and purification.
- Designed for contaminated, dense and viscous liquids.
- Oils.

#### Remarks:

Due to the complexity, variety and large number of particular specifications for each installation, along with the existence of diverse factors which can affect the working conditions and nature of the product, it is the responsibility of the end-user to carry out the necessary tests to ensure the proper functioning of the product in any specific application. Product installation must be carried out and maintained following the good practice codes and/or updated technical standards.

Rev.4-06.24

1/3



Polígono Industrial ATUSA - Agurain S/N - 01200 Salvatierra (Alava) España  
Tel.: (+34) 945 18 00 00 Fax : (+34) 945 30 01 53 e-mail: [ventas@atusagroup.com](mailto:ventas@atusagroup.com)  
[www.atusagroup.com](http://www.atusagroup.com)

# 550

## VÁLVULA DE RETENCIÓN DE BOLA - BRIDADA BALL CHECK VALVE - FLANGED

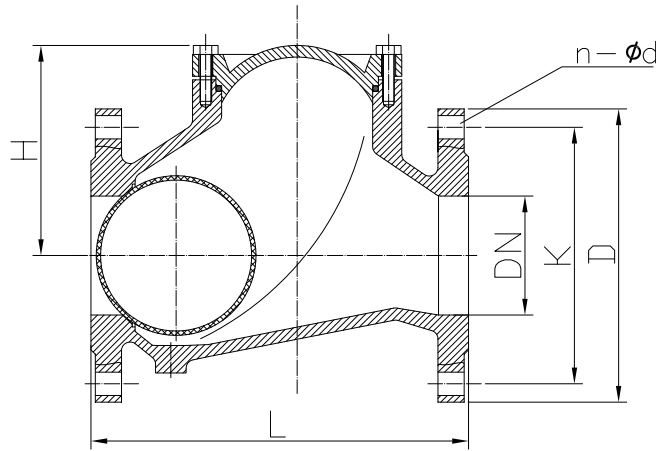

### INFORMACIÓN TÉCNICA - TECHNICAL INFORMATION

DN	COD.	DIMENSIONES - DIMENSIONS						Peso aprox. Weight approx. (Kg)
		L (mm)	H (mm)	Brida/Flange EN 1092-2 PN 10/16				
				PN	D (mm)	K (mm)	n - Ød (mm)	
40	VF550040	180	98	10/16	150	110	4 - 19	7,0
50	VF550050	200	106	10/16	165	125	4 - 19	7,5
65	VF550065	240	129	10/16	185	145	4 - 19	11,0
80	VF550080	260	146	10/16	200	160	8 - 19	15,0
100	VF550100	300	194	10/16	220	180	8 - 19	22,0
125	VF550125	350	207	10/16	250	210	8 - 19	34,0
150	VF550150	400	240	10/16	285	240	8 - 23	46,0
200	VF550201	500	322	10	340	295	8 - 23	90,0
200	VF550200	500	322	16	340	295	12 - 23	90,0
250	VF550251	600	388	10	395	350	12 - 23	163,0
250	VF550250	600	388	16	405	355	12 - 28	163,0
300	VF550301	700	458	10	445	400	12 - 23	230,0
300	VF550300	700	458	16	460	410	12 - 28	230,0
350	VF550351	800	610	10	505	460	16 - 23	316,0
350	VF550350	800	610	16	520	470	16 - 28	316,0
400	VF550401	900	705	10	565	515	16 - 28	422,0
400	VF550400	900	705	16	580	525	16 - 31	422,0

Rev.4-06.24  
2/3



Polígono Industrial ATUSA - Agurain S/N - 01200 Salvatierra (Alava) España  
Tel.: (+34) 945 18 00 00 Fax : (+34) 945 30 01 53 e-mail: [ventas@atusagroup.com](mailto:ventas@atusagroup.com)  
[www.atusagroup.com](http://www.atusagroup.com)

**DIAGRAMA PÉRDIDAS DE CARGA - HEAD LOSS CHART**

(Agua en flujo horizontal a 20 °C - Water in horizontal flow at 20 °C)

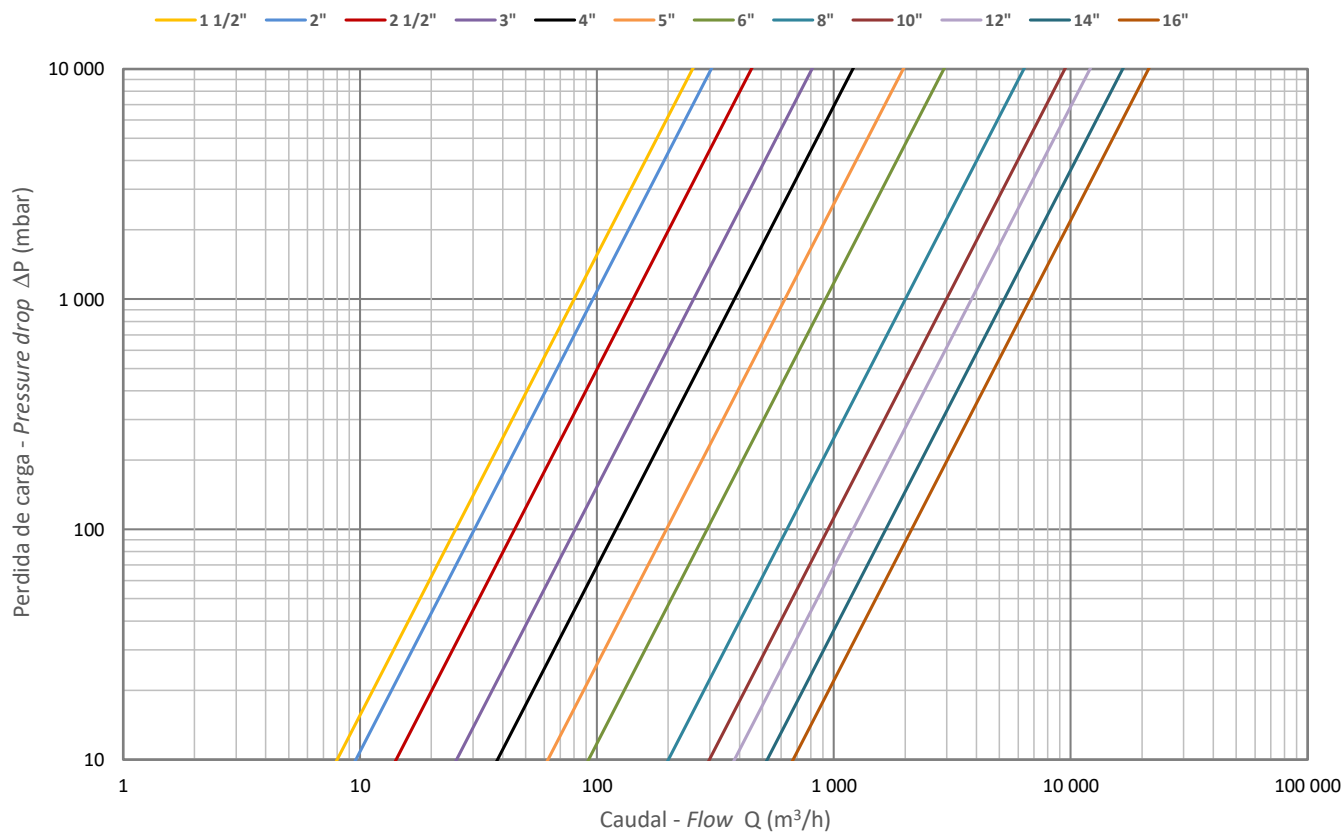

Nota: 1 mca = 100 mbar

Medida - Size (inches)	1 1/2"	2"	2 1/2"	3"	4"	5"	6"	8"	10"	12"	14"	16"
Diámetro nominal - Nominal size	DN 40	50	65	80	100	125	150	200	250	300	350	400
Coefficiente de caudal - Flow coefficient	Kv 80	96	142	255	380	620	920	2000	2980	3800	5230	6720

Kv : coeficiente que expresa el caudal circulante (expresado en m<sup>3</sup>/h) a través de la valvula generando una caída de presión a su paso de 1 bar (1000 mbar)  
*Kv: is the rate of flow (in cubic metres per hour) at a pressure drop of 1 bar (1000 mbar) through the valve*

Nota : Debido al constante desarrollo de nuestros productos, los datos suministrados pueden ser alterados sin previo aviso.

Note : Due to the continuous development of our products, specifications may be changed without notification at any time.

Rev.4-06.24

3/3