

570

VÁLVULA DE BOLA BRIDADA FLANGED ENDS BALL VALVE

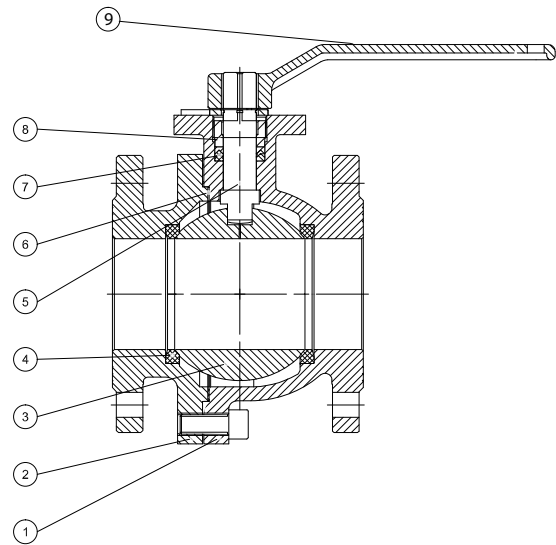

DESCRIPCIÓN COMPONENTES - COMPONENTS DESCRIPTION

Ítem	Descripción - Description	Material - Material
1	Cuerpo - Body	Fundición Gris - Grey Cast Iron GG 25 (EN-GJL-250)
2	Tapa - Bonnet	Fundición Gris - Grey Cast Iron GG 25 (EN-GJL-250)
3	Bola - Ball	Acero Inoxidable - Stainless Steel AISI 304
4	Asiento - Seat	PTFE
5	Eje - Stem	Acero Inoxidable - Stainless Steel AISI 304
6	Junta - Gasket	PTFE
7	Empaquetadura - Stem Packing	PTFE
8	Tuerca - Gland Nut	Acero Carbono - Carbon Steel
9	Palanca - Hand Lever	Fundición Gris - Grey Cast Iron GG 25 (EN-GJL-250)

CARACTERÍSTICAS BÁSICAS

- Presión de trabajo: PN 16.
- Temperatura de trabajo: -10 °C a 150 °C.
- Distancia entre bridas: DIN 3202-1 F18 (UNE-EN 558-1 Serie 27).
- Bridas según: DIN 2501 (UNE-EN 1092-2 PN 10 / 16).
- Brida montaje actuador ISO 5211.
- Conexión mediante bridas.
- Válvula de cierre rápido, todo o nada, 1/4 de vuelta, giro 90°.
- Paso recto y total.
- Diseño bidireccional.
- Mínima pérdida de carga.

APLICACIONES GENERALES

- Sistemas de aguas generales.
- Plantas de abastecimiento, bombeo y acometidas de aguas.
- Aplicaciones industriales a bajas presiones y temperaturas.
- Conducciones de agua para riego.
- Obra hidráulica y civil.
- Climatización.
- Aceites lubricantes y aire comprimido.

BASIC FEATURES

- Working pressure: PN 16.
- Working temperature: -10 °C to 150 °C.
- Face to face dimension: DIN 3202-1 F18 (EN 558-1 Serie 27).
- Flange dimension: DIN 2501 (EN 1092-2 PN 10 / 16).
- Top flange ISO 5211 for actuator coupling.
- Flanged end connections.
- Quick closing valves, quarter turn for on/off service, 90° operation.
- Straight and full bore.
- Bidirectional design.
- Minimum drop pessure.

GENERAL APPLICATIONS

- Water systems.
- Water supply, pumping and connection plants.
- Low pressure and low temperature industrial applications.
- Irrigation systems.
- Hydraulic and civil works.
- HVAC systems.
- Lubricating oil and air compressed.

Rev.1-01.20
1/3



Polígono Industrial ATUSA - Agurain S/N - 01200 Salvatierra (Alava) España
Tel.: (+34) 945 18 00 00 Fax : (+34) 945 30 01 53 e-mail: ventas@atusagroup.com
www.atusagroup.com

570

VÁLVULA DE BOLA BRIDADA FLANGED ENDS BALL VALVE

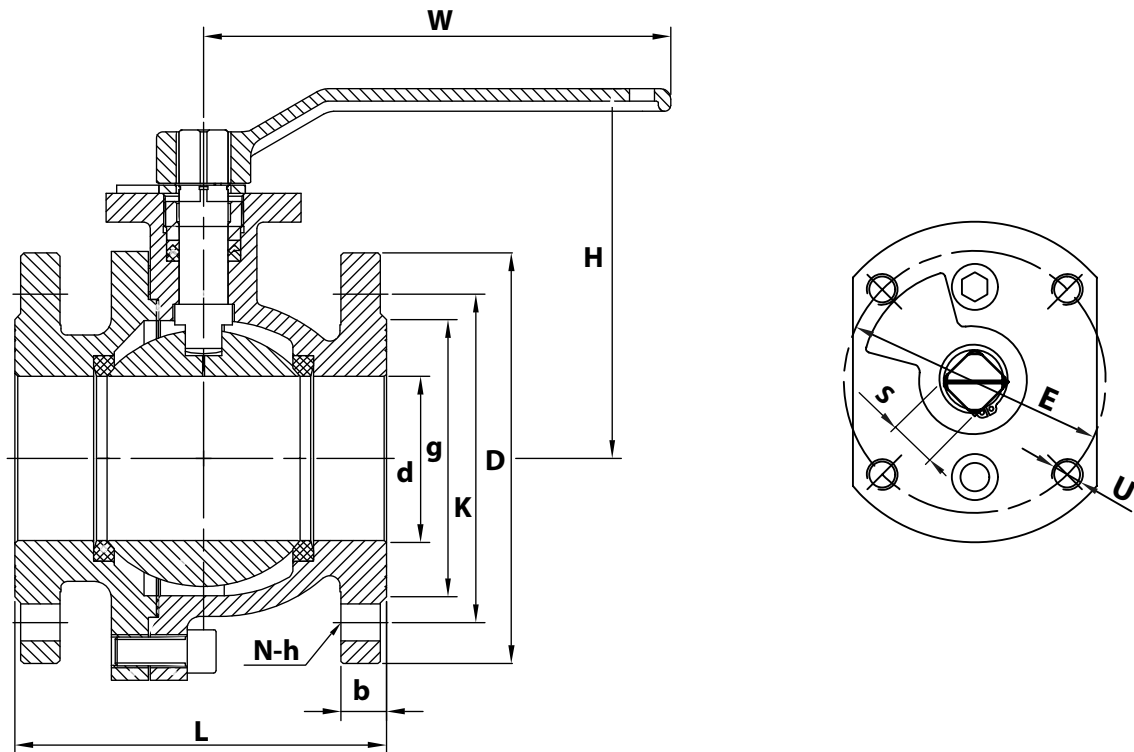

INFORMACIÓN TÉCNICA - TECHNICAL INFORMATION

DN	COD.	DIMENSIONES - DIMENSIONS (mm)														Peso aprox. Weight approx. (Kg)
		d	L	H	W	Brida / Flange EN 1092-2 PN 10/16						Brida / Flange ISO 5211				
						PN	D	k	g	b	N - h	E	U	S		
15	VF570015	15	115	86	130	10/16	95	65	45	14	4 - 14	F04	42	M5	9 x 9	2,8
20	VF570020	20	120	95	130	10/16	105	75	58	16	4 - 14	F04	42	M5	9 x 9	3,6
25	VF570025	25	125	100	160	10/16	115	85	68	16	4 - 14	F04	42	M5	12 x 12	4,5
32	VF570032	32	130	105	160	10/16	140	100	78	18	4 - 19	F05	50	M6	12 x 12	6,3
40	VF570040	40	140	121	220	10/16	150	110	88	18	4 - 19	F05	50	M6	14 x 14	7,8
50	VF570050	50	150	136	240	10/16	165	125	102	20	4 - 19	F07	70	M8	17 x 17	9,9
65	VF570065	65	170	161	330	10/16	185	145	122	20	4 - 19	F10	102	M10	19 x 19	15,5
80	VF570080	80	180	180	330	10/16	200	160	138	22	8 - 19	F10	102	M10	19 x 19	20,1
100	VF570100	100	190	222	400	10/16	220	180	158	24	8 - 19	F10	102	M10	22 x 22	26,3
125	VF570125	125	325	260	645	10/16	250	210	188	26	8 - 19	F12	125	M12	27 x 27	47,3
150	VF570150	150	350	280	645	10/16	285	240	212	26	8 - 23	F14	140	M16	27 x 27	67,4
200	VF570200	200	400	340	860	16	340	295	268	30	12 - 23	F16	165	M20	30 x 30	105,8

Observaciones:

Dada la complejidad, variedad y gran cantidad de especificaciones particulares de cada instalación, en conjunción con la existencia de diversos factores que pueden afectar a las condiciones de trabajo y naturaleza del producto, es responsabilidad del usuario final realizar los ensayos necesarios para garantizar el correcto funcionamiento del producto en cada aplicación concreta.

La instalación del producto deberá realizarse y mantenerse siguiendo códigos de buena práctica y/o estándares existentes.

Remarks:

Due to the complexity, variety and large number of particular specifications for each installation, along with the existence of diverse factors which can affect the working conditions and nature of the product, it is the responsibility of the end-user to carry out the necessary tests to ensure the proper functioning of the product in any specific application.

Product installation must be carried out and maintained following the good practice codes and/or updated technical standards.

Rev.1-01.20
2/3



Polígono Industrial ATUSA - Agurain S/N - 01200 Salvatierra (Alava) España
Tel.: (+34) 945 18 00 00 Fax : (+34) 945 30 01 53 e-mail: ventas@atusagroup.com
www.atusagroup.com



DIAGRAMA PÉRDIDAS DE CARGA / HEAD LOSS CHART

(Agua en flujo horizontal a 20 °C / Water in horizontal flow at 20 °C)

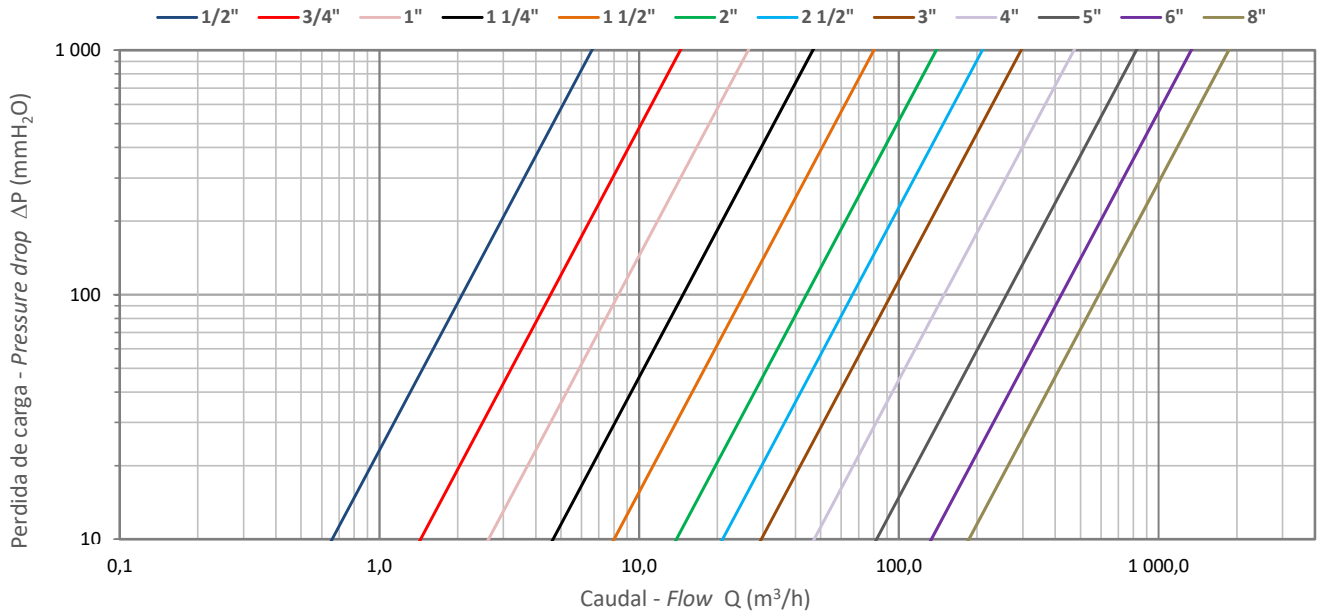

Nota: 1000 mmH₂O = 0,1 bar

Medida - Size (inches)	1/2"	3/4"	1"	1 1/4"	1 1/2"	2"	2 1/2"	3"	4"	5"	6"	8"
Diámetro nominal - Nominal size DN	15	20	25	32	40	50	65	80	100	125	150	200
Coefficiente de caudal - Flow coefficient Kv	21	46	84	149	256	445	670	945	1510	2625	4265	5950

Kv : coeficiente que expresa el caudal circulante (expresado en m³/h) a través de la valvula generando una caída de presión a su paso de 1 bar (1000 mbar)

Kv: is the rate of flow (in cubic metres per hour) at a pressure drop of 1 bar (1000 mbar) through the valve

DIAGRAMA PRESIÓN - TEMPERATURA / PRESSURE - TEMPERATURE DIAGRAM

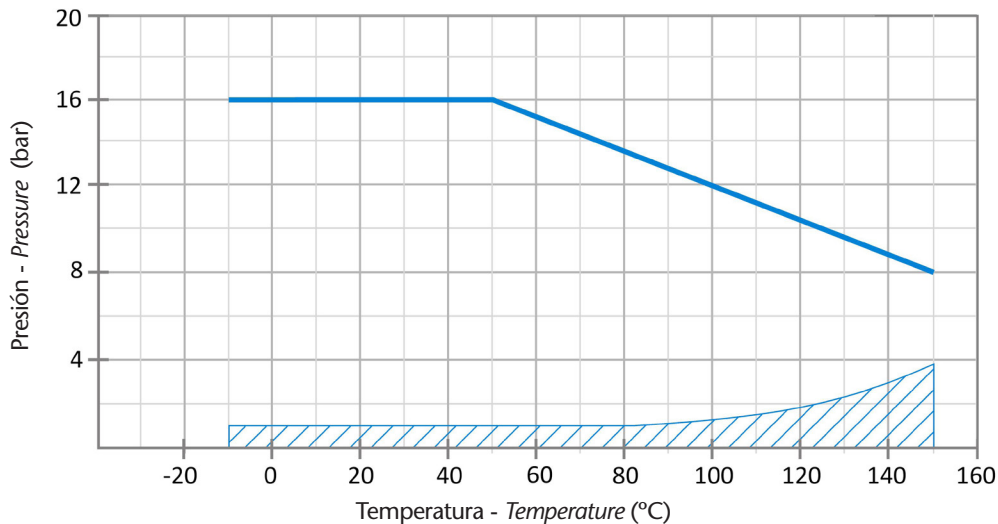

Nota : atención a la curva de saturación Líquido-Vapor para agua (se recomienda no utilizar en la zona rayada).

Note : attention to water saturation Liquide-Vapour curve (it is recommended don't use under saturation line, hatched area).

Nota : Debido al constante desarrollo de nuestros productos, los datos suministrados pueden ser alterados sin previo aviso.

Note : Due to the continuous development of our products, specifications may be changed without notification at any time.

Rev.1-01.20

3/3